

9mm BSP Machine Gun

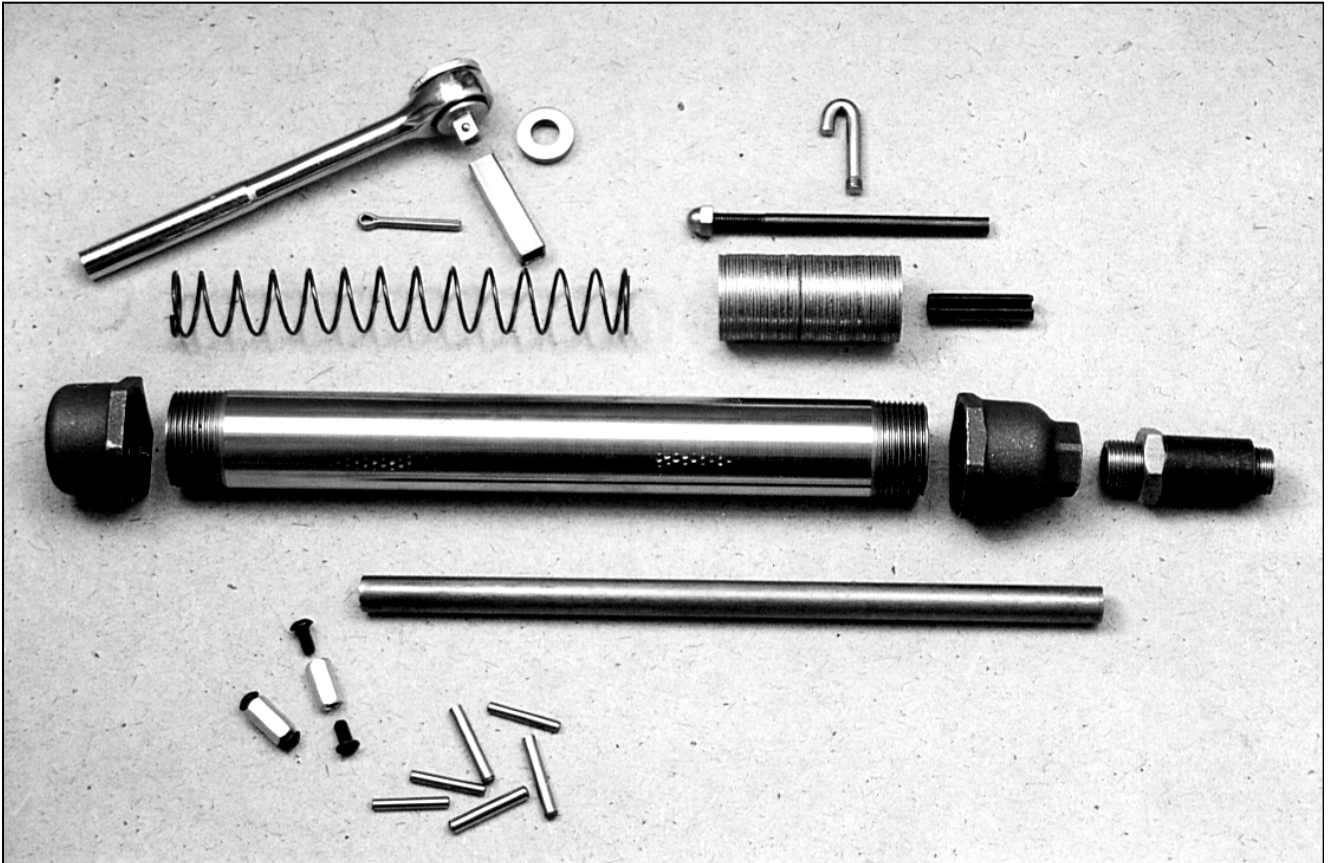

Legal Note.

The weapon shown in the following document has not been built and is a prototype design only.

All photo's depict plumbing / hardware products and components which are shown in their unmodified "as bought" condition.

For accademic study purposes only.

The 9mm 'BSP' Sub - Machine Gun

The following design drawings illustrate the construction of a 9mm sub-machine gun utilizing off the shelf 'British Standard Pipe' (BSP) Fittings. BSP fittings, commonly known as 'Malleable Iron Fittings', are readily available from most good trade plumbing outlets. Because this BSP machine gun design uses some of the same components seen in '*Expedient Homemade Firearms*' Volume I, I have not discussed their manufacture again here, for fear of boring the reader, and myself. The magazine and magazine well being two examples. The following design is offered on the understanding that the

reader is already familiar with the firearm construction methods shown in my previous '*Expedient Homemade Firearms*' books. I will leave the reader to decide whether this design is good, bad, or somewhere in between!

MATERIALS REQUIRED

1. 1-1/4" BSP tube x 12 1/2" length.
2. 2.5mm steel sheet (x2) 9-3/4" length.
3. 40x20 x 2.5mm tube.
4. 34.93x 15.88 x 1.6mm tube
5. 20g x 3/8" spring steel.
6. 1/8" steel plate.
7. 1/4" " "
8. 1/4" " "
9. 5/8"x 14g steel sheet.
10. 6mm studding connectors x 2.
11. 6mm cap screws x 4.
12. Dowel pins, 4 & 6 mm dia.
13. 1" x 1/8" round tube.
14. 35mm dia' rubber stock.
15. 1 1/4" x 1/2" BSP Reducer.
16. 1/2" BSP Socket.
17. 1/2" BSP Lock Nut.
18. 1/2" BSP Threaded Tube.
19. 1 1/4" BSP Cap.
20. 15.88 x 3. 25mm Hydraulic tube.
21. Assorted nuts and bolt.

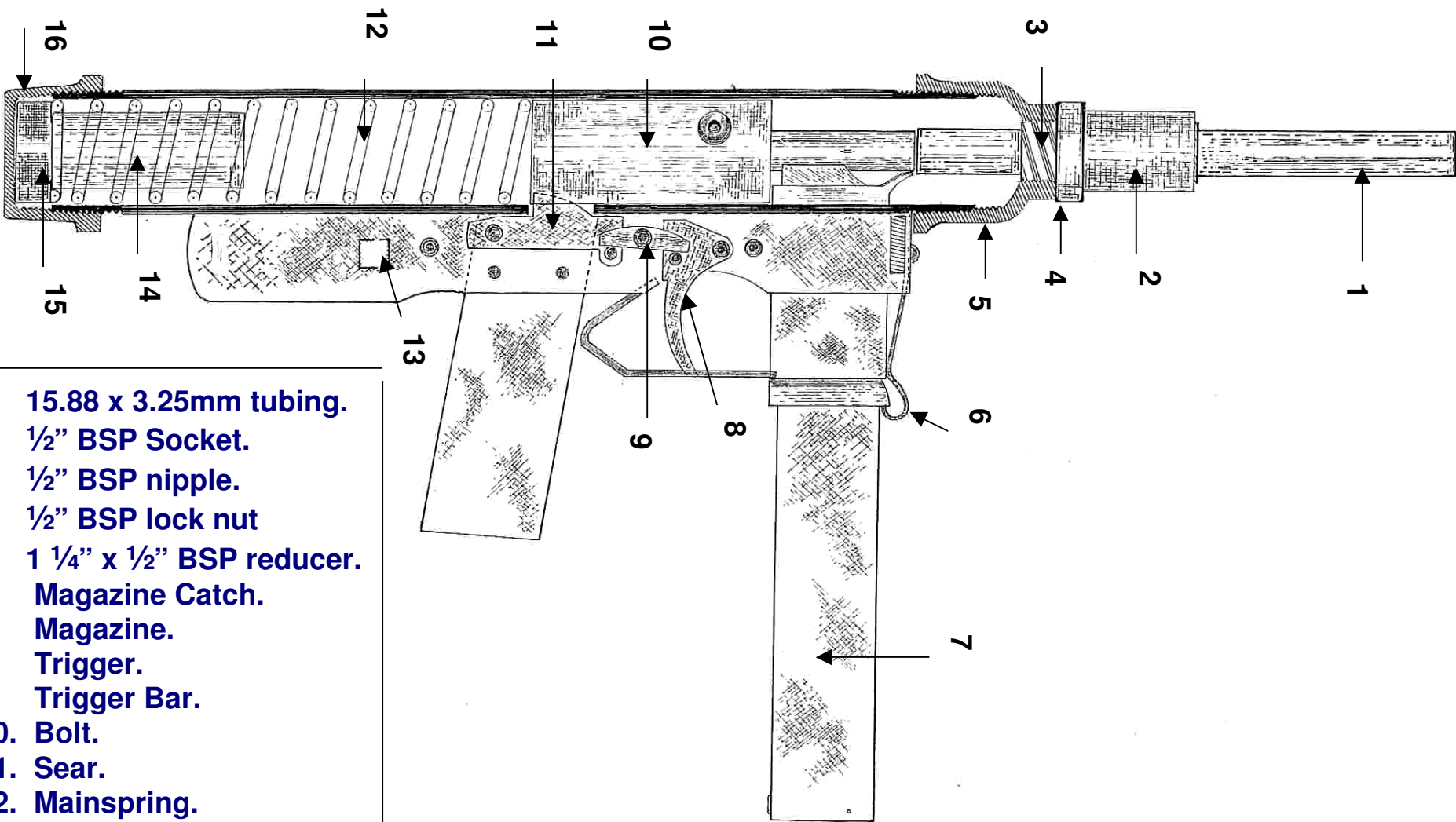

1. 15.88 x 3.25mm tubing.
2. 1/2" BSP Socket.
3. 1/2" BSP nipple.
4. 1/2" BSP lock nut
5. 1 1/4" x 1/2" BSP reducer.
6. Magazine Catch.
7. Magazine.
8. Trigger.
9. Trigger Bar.
10. Bolt.
11. Sear.
12. Mainspring.
13. Stock anchor point.
14. 1" Diameter x 1/8" tube.
15. Rubber buffer.
16. 1 1/4" BSP pipe Cap.

TEMPLATES

(Internal Components. Hole Diameters Arrowed)

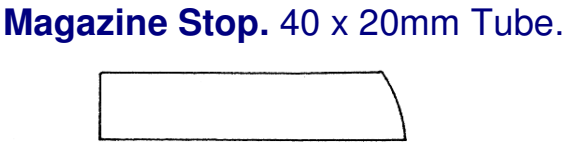
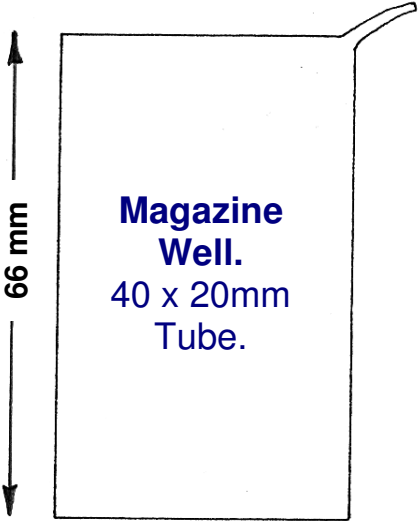
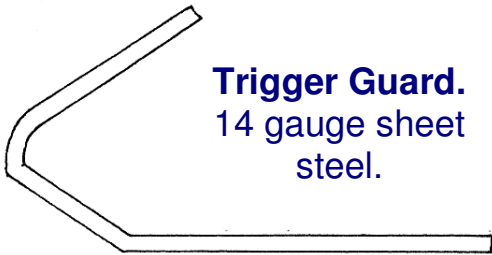
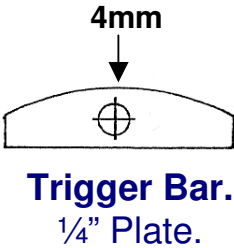
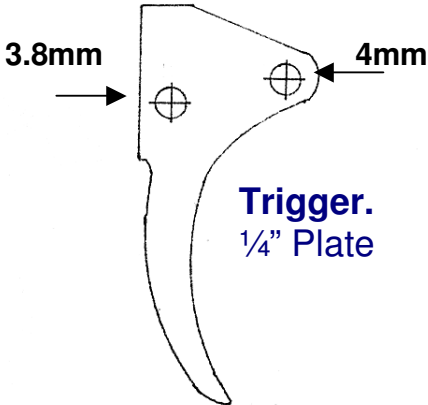
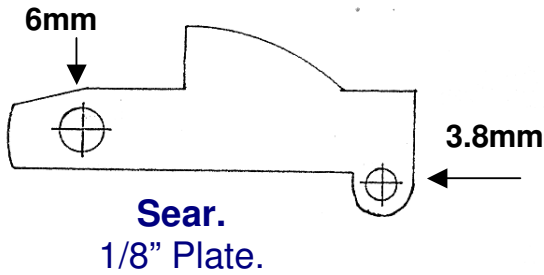

LOWER RECEIVER TEMPLATE

(Hole diameters shown in millimetres)

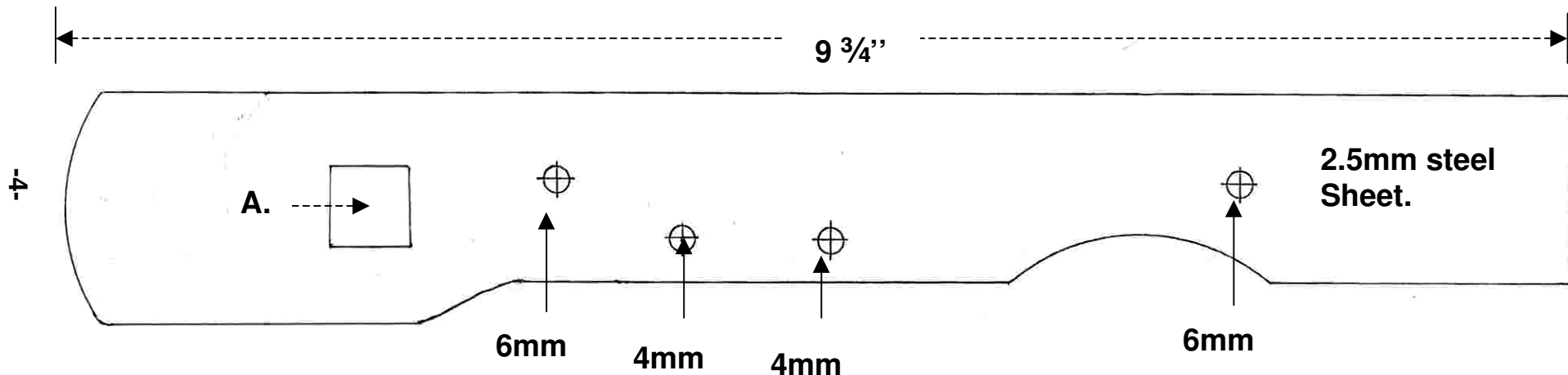

The lower receiver is composed of two receiver side- plates, each being $9\frac{3}{4}$ " in length. Each plate is identical. Each side - plate is cut from a length of 2.5mm thick steel sheet to the shape of the above template. The square recess shown in figure 'A' is the anchor point for the shoulder stock. This measures $\frac{1}{2}$ " square.

Note: If the template is not $9\frac{3}{4}$ " in length when printed, it may be enlarged using a photocopier until the necessary length is achieved.

LOWER RECEIVER ASSEMBLY

To create the lower receiver assembly, the two receiver side-plates are joined together by spacing them between two 6mm studding connectors, (A and B). Four dome head cap screws are then screwed into the connectors and thoroughly tightened, effectively holding the assembly together. The two connectors must be *exactly* 20mm in length. As bought, 6mm connectors are usually this exact length, but if they are not, they may be trimmed on a lathe until the required length is achieved. A section of steel plate measuring 20 x 20mm is now silver soldered between the two side-plates in the position shown at 'C' below. The plate should be $\frac{1}{4}$ " thick. A gap of 2mm should now exist between the plate and the end of the receiver.

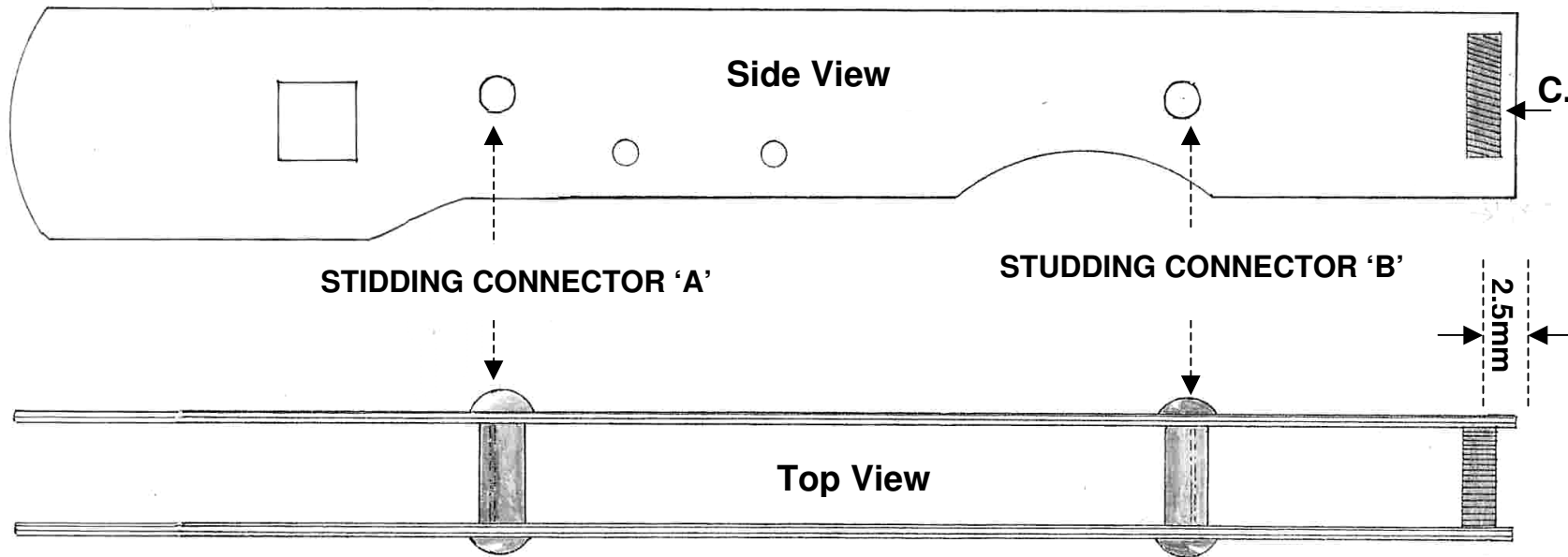

LOWER RECEIVER: WELL AND GUARD FITTED

The magazine well is inserted into the receiver and welded in place along points 'A' and 'B'.
Note: Do not weld along opposite side of point 'B'. It must be ensured before welding that the top edge of the well is 7mm above the top edge of the receiver.

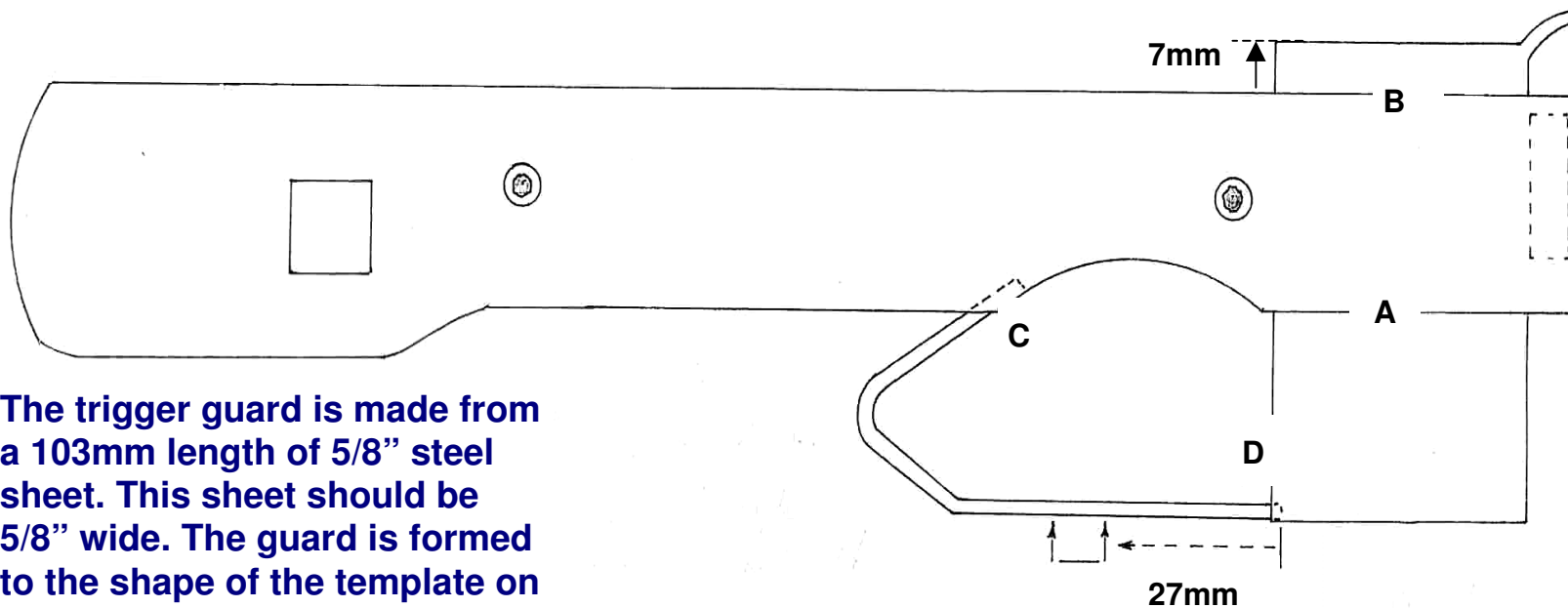

The trigger guard is made from a 103mm length of 5/8" steel sheet. This sheet should be 5/8" wide. The guard is formed to the shape of the template on page 3.

A hole measuring 9x7mm is cut through the guard, 27mm from its front edge. This hole will accept the lower leg of the trigger. The guard is silver soldered in position at points 'C' and 'D'.

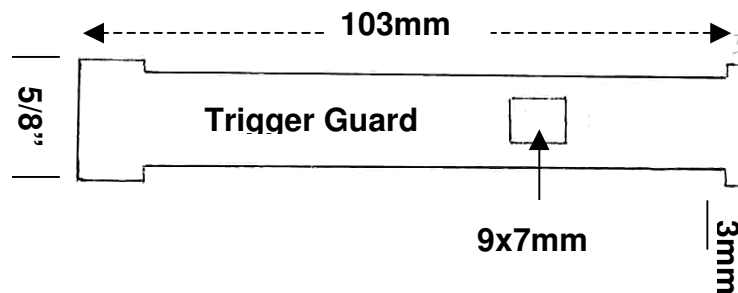

PISTOL GRIP

The grip is the next part to make.

It is made from a 112mm length of 40 x 20mm tubing.

A 5.8mm diameter hole is drilled through the grip in the position shown in the accompanying grip template.

Before the grip is fixed to the receiver the sear must be made and fitted. See page 8.

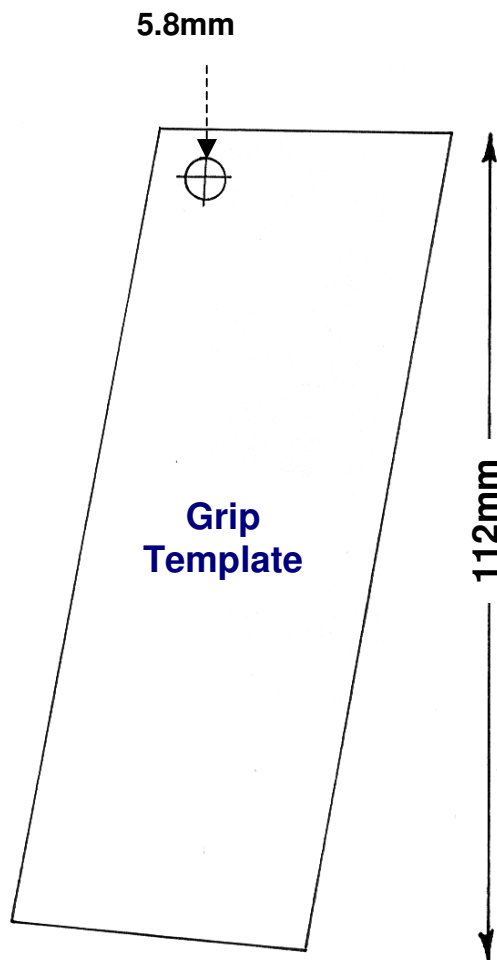

SEAR CONSTRUCTION

The sear is cut from a section of 1/8" thick steel plate. See templates, page 3.

A 4mm diameter dowel pin is tapped into the sears 3.8mm hole.

The pin should protrude 8mm from the sears right side when fitted.

The sear is made from mild steel and should be case hardened after final shaping.

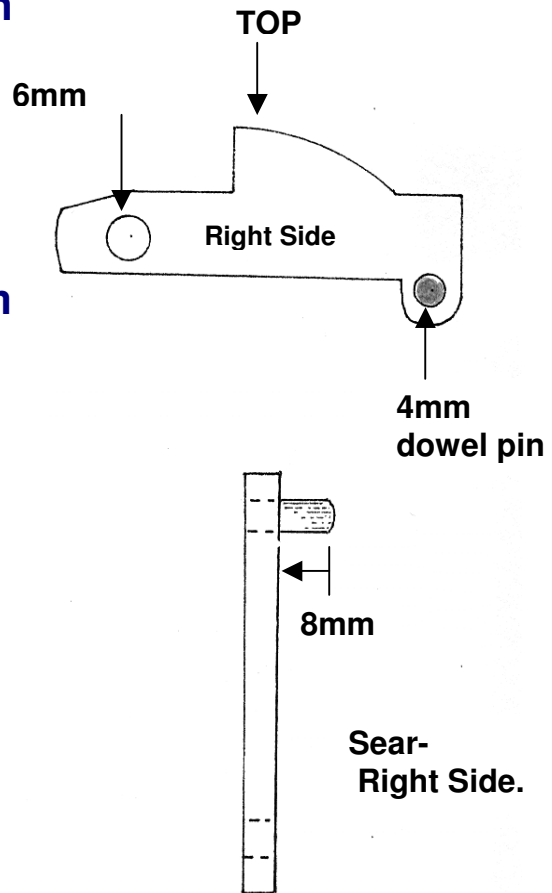

TRIGGER

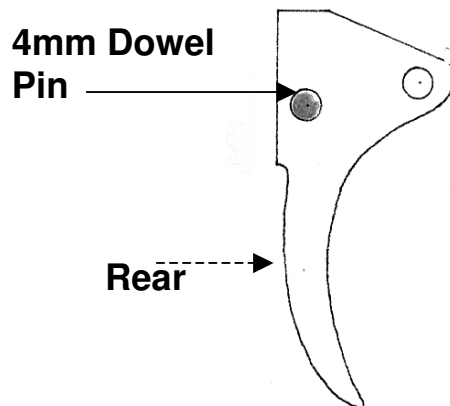

**Pin must protrude
6mm from each
side of trigger.**

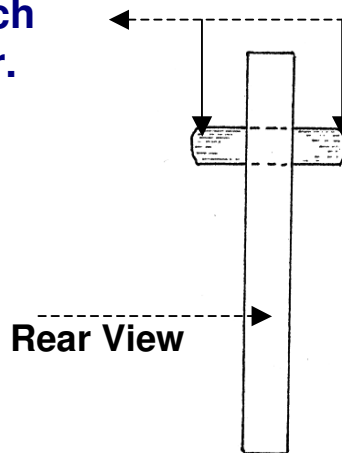

The trigger is made from a section of 1/4" thick steel plate. A 4mm diameter dowel pin (a spring pin could be used as a substitute) is tapped into the 3.8mm hole. The pin must protrude 6mm from each side of the trigger when fitted.

FITTING THE SEAR

Before the sear is fitted, a slot is cut through the rear and front of the grip wall. The slot is 15mm deep and 4mm wide. The sear is inserted into this slot and retained with a 6mm diameter dowel pin. This pin should be 20mm in length.

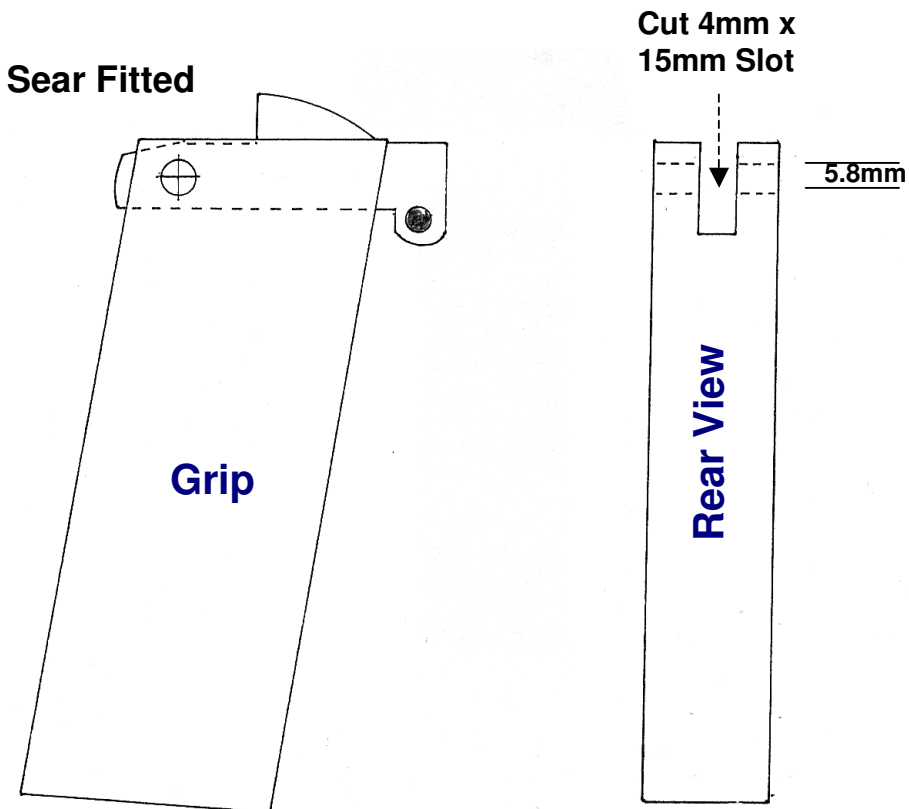

Spring Fitted

The sear spring is formed from 20g spring wire to the shape illustrated opposite. It should have between four and six coils.

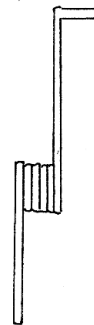
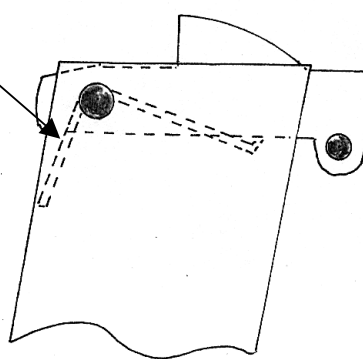

Sear Spring

GRIP ASSEMBLY FITTED

The grip and sear assembly is inserted into the receiver and retained with two dowel pins.

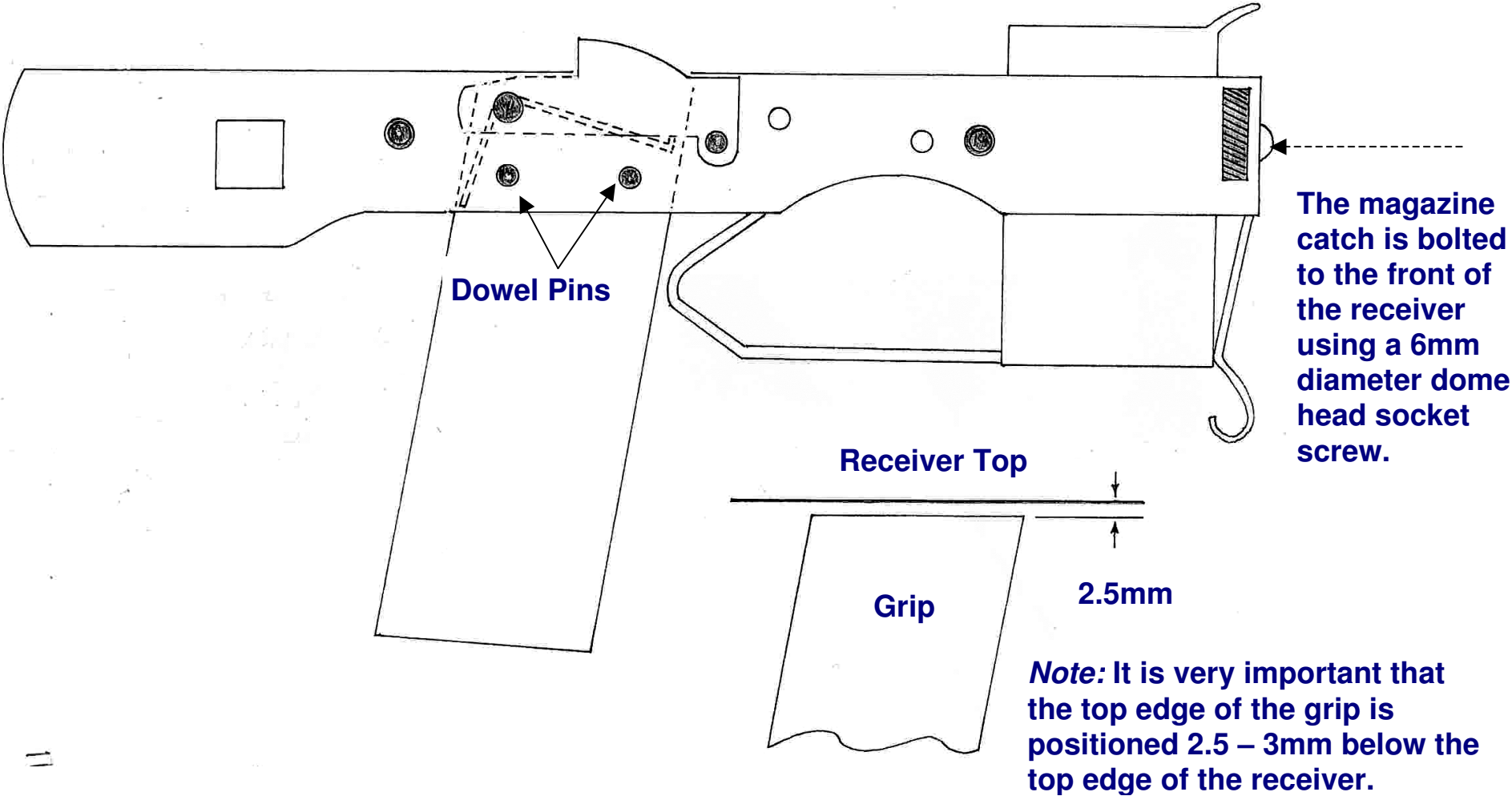

-11-

FULLY ASSEMBLED LOWER RECEIVER

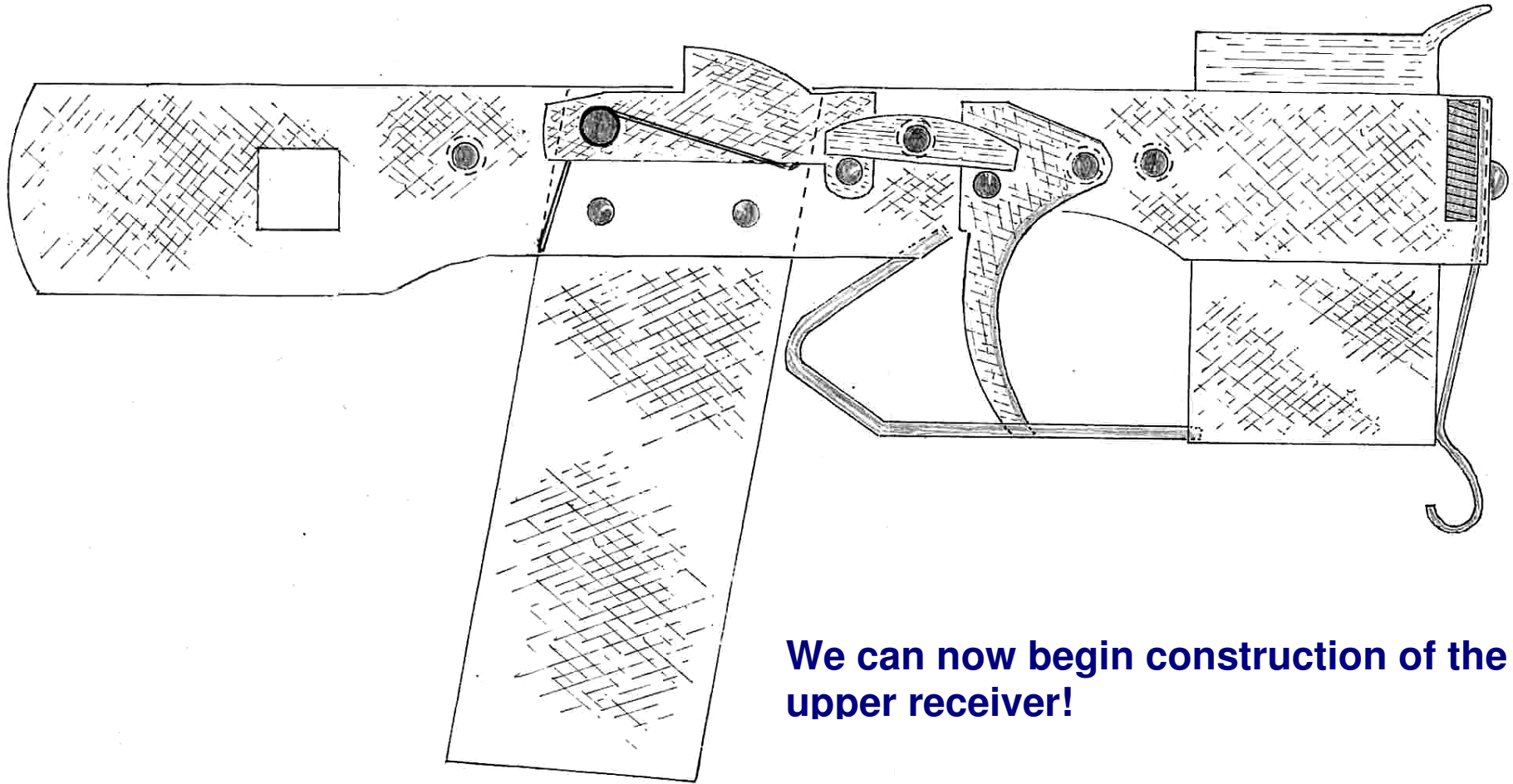

We can now begin construction of the upper receiver!

PHOTO OF UPPER RECEIVER COMPONENTS

The upper receiver assembly consists of a 1¼” BSP tube (screwed at both ends) and fitted with a Cap and Reducer, as photo ‘A’ below illustrates. Photo ‘B’ shows the reducer and cap screwed onto the receiver tube and the barrel assembly ready for fitting.

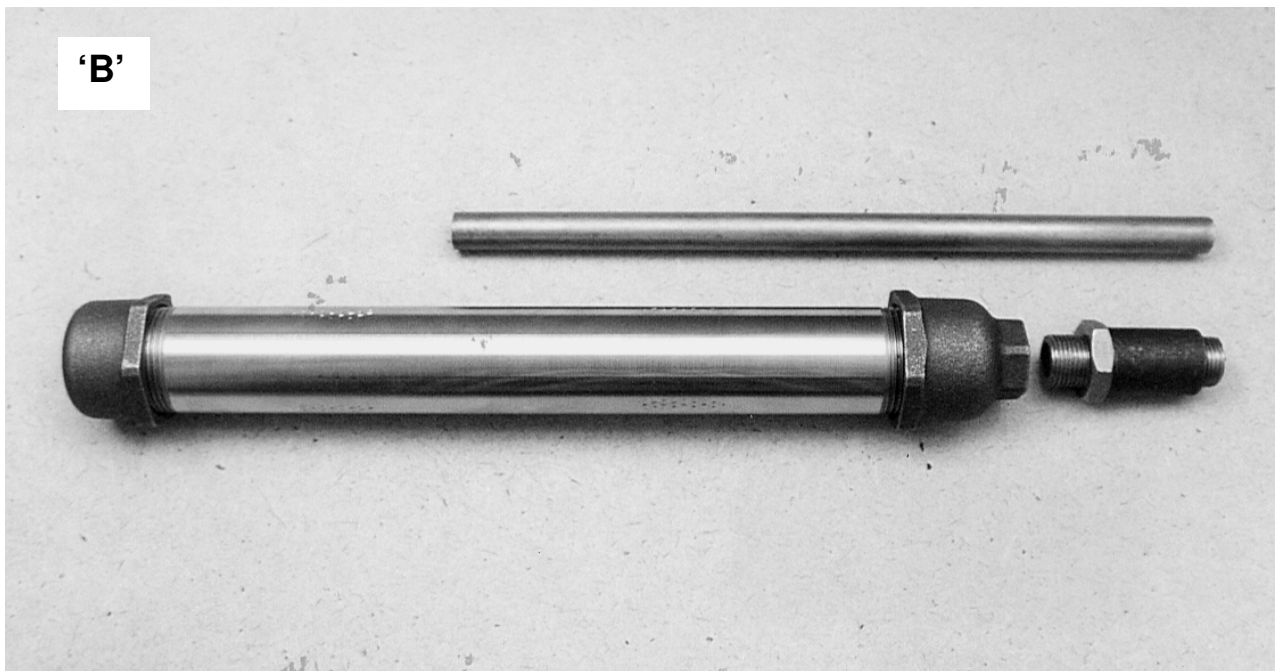

UPPER RECEIVER TEMPLATE

The upper receiver template must be enlarged using a photocopier until it is 12 1/2" in length. Once enlarged, the template is glued around the 1 1/4" BSP upper receiver tube. The recesses for the ejection port, magazine well (EP&MW), bolt handle, and sear, can then be marked onto the receiver tube.

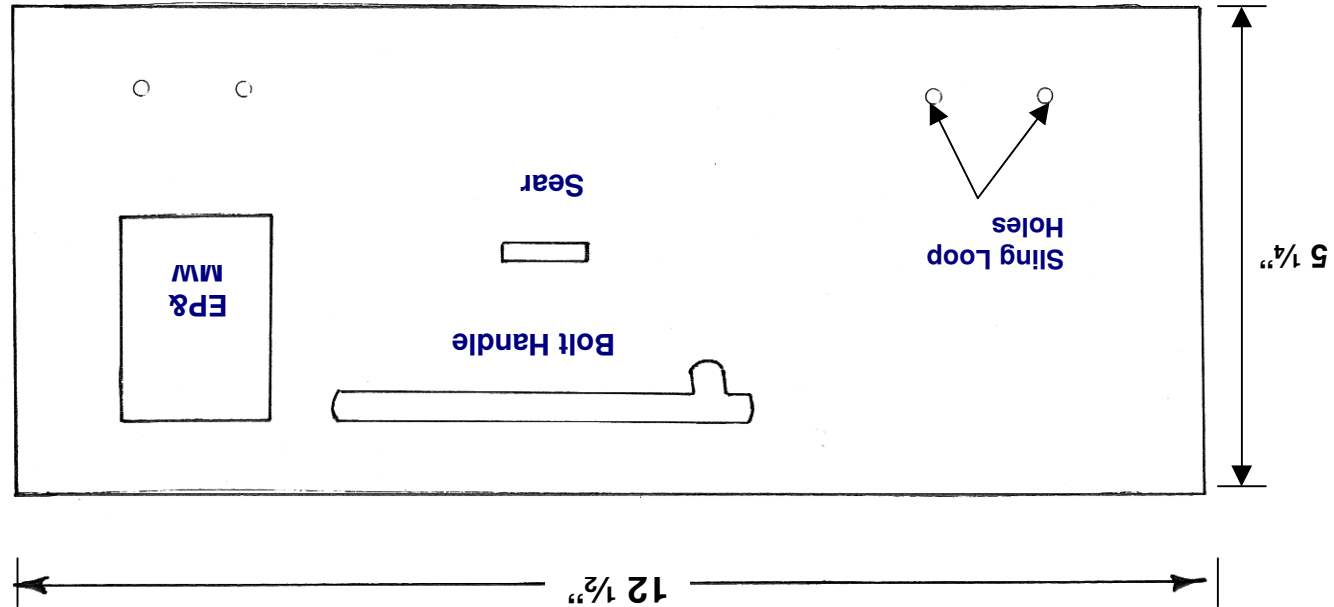
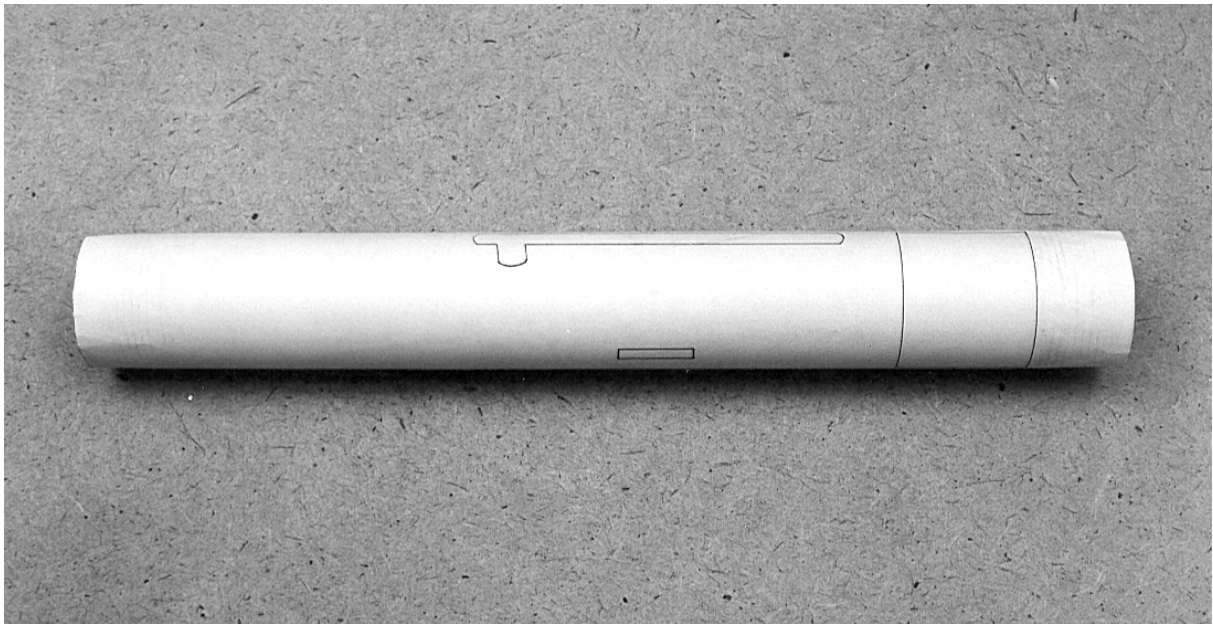

PHOTO OF TEMPLATE ATTACHED TO **UPPER RECEIVER TUBE**

The template is attached to the upper receiver tube to allow the necessary recesses to be marked onto the tube.



UPPER RECEIVER

Thread length: 1-1/8"

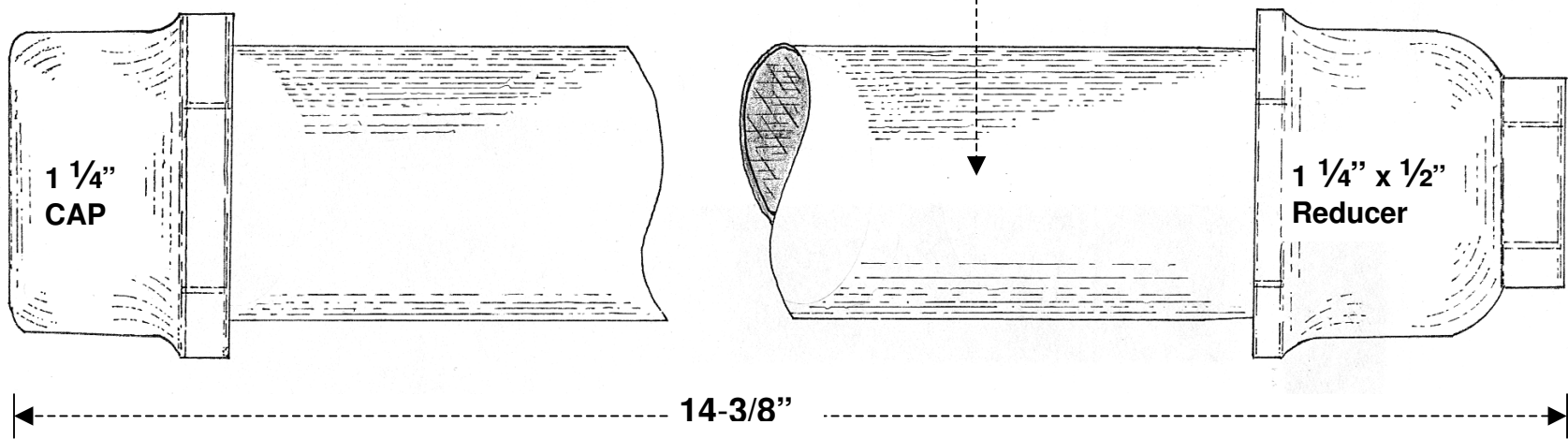
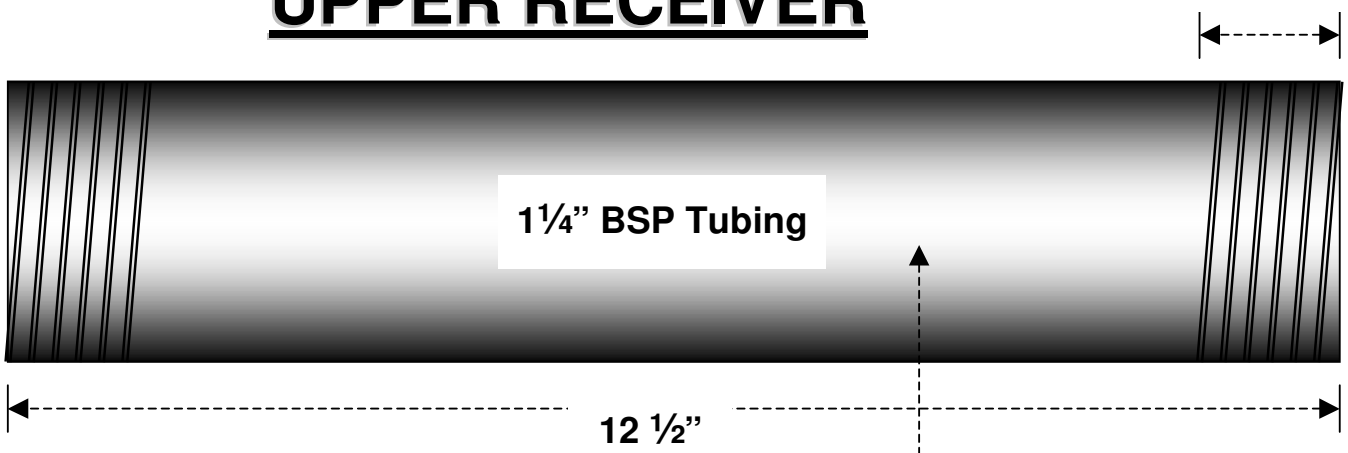

-16-

Expedient Homemade Firearms. BSP-SMG

BARREL ASSEMBLED

(The barrel is assembled from 'BSP' pipe fittings)

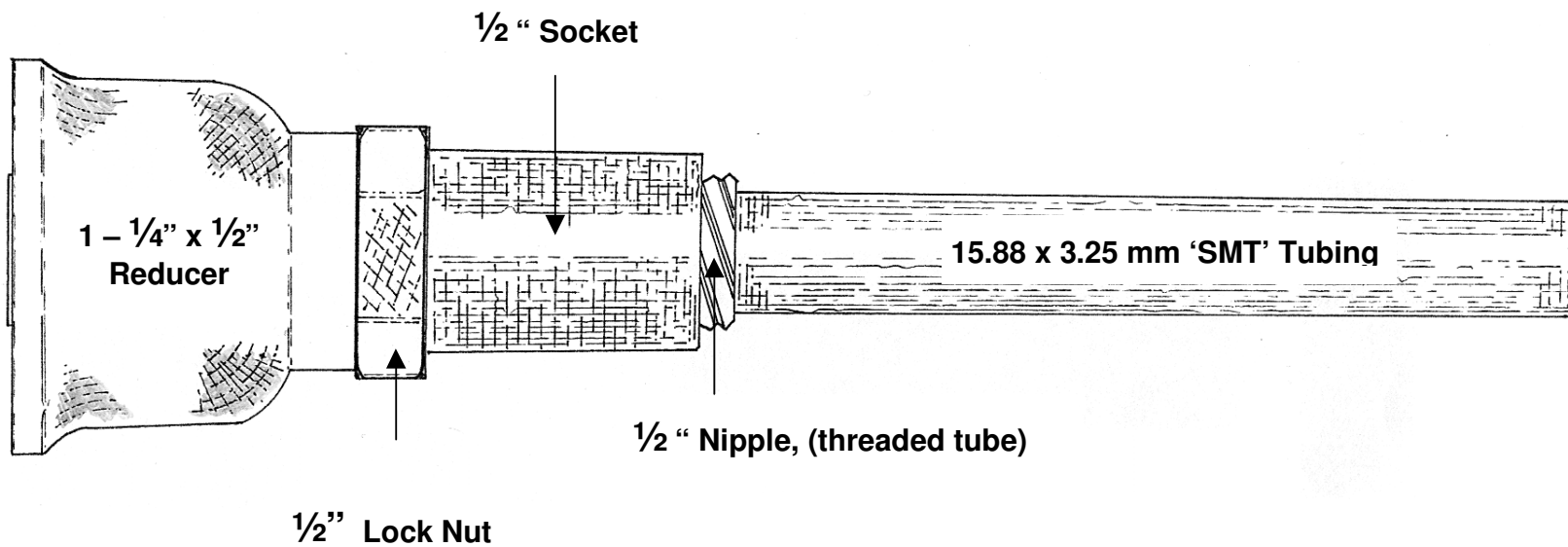
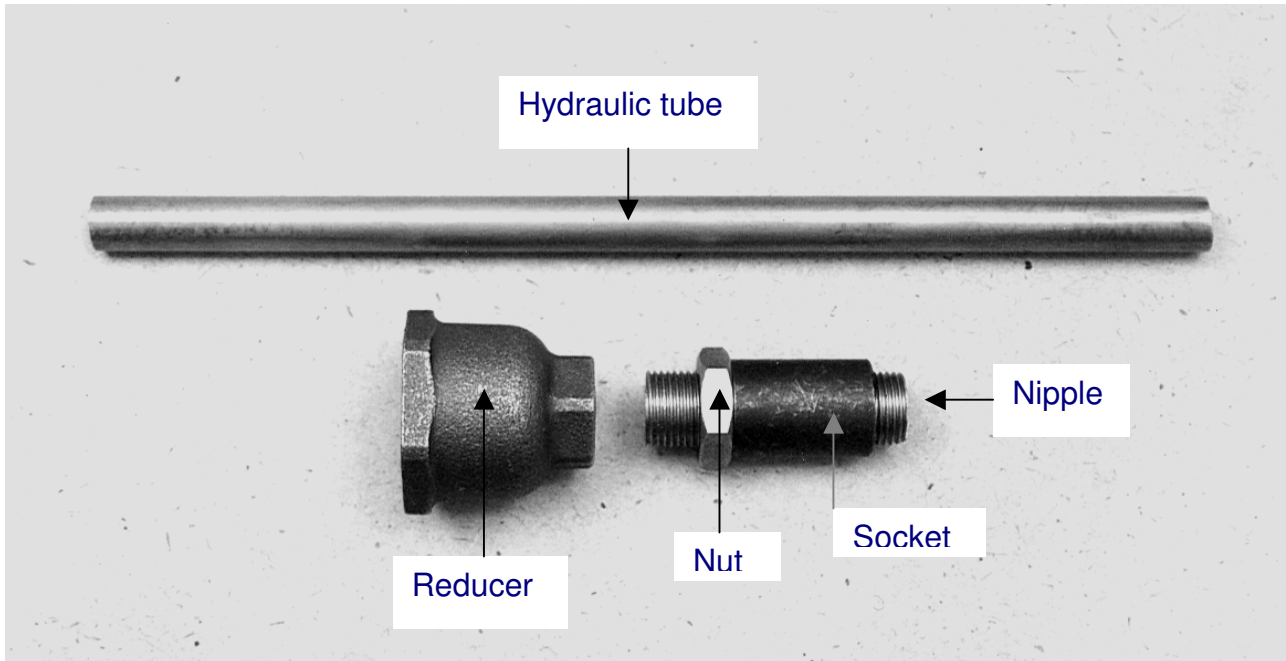

PHOTO OF BARREL COMPONENTS

The barrel is assembled from a length of 15.88 x 3.25mm hydraulic tubing, a 1¼" BSP Reducer, ½" BSP Lock nut, ½" BSP Socket, and a ½" BSP Nipple, (threaded tube).



BOLT ASSEMBLY

The bolt is machined to the following dimensions from a suitable section of round steel stock.

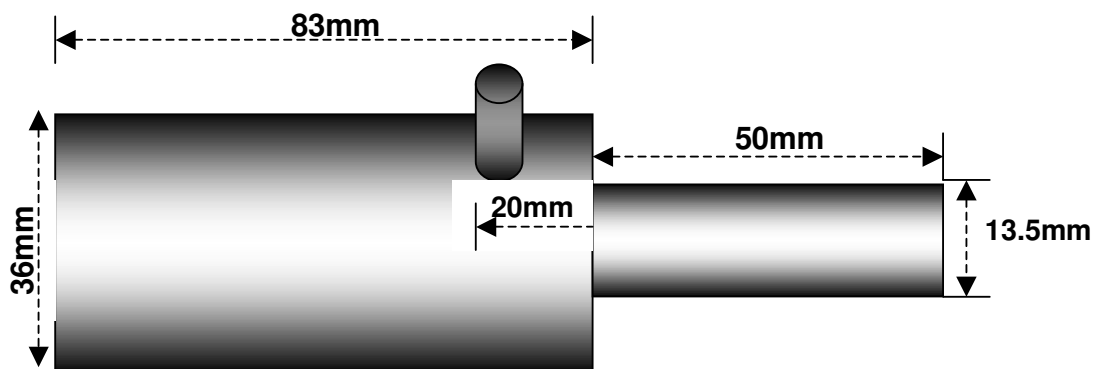

BUFFER AND SPRING GUIDE

The buffer is made from a section of hard rubber stock to the following dimensions.

The spring guide is nothing more than a length of 1" diameter tubing.

The tubing should have a wall thickness of 1/8".

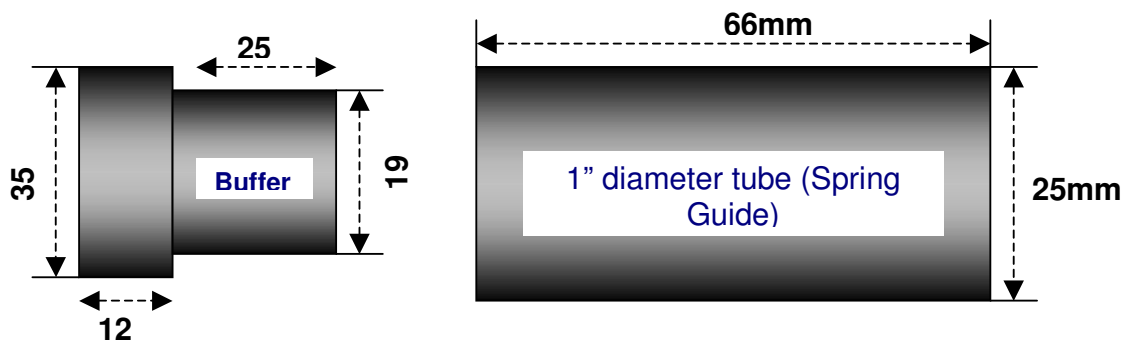

ALTERNATIVE BOLT CONSTRUCTION METHOD

An alternative to machining the SMG bolt would be to assemble it from the components illustrated below.

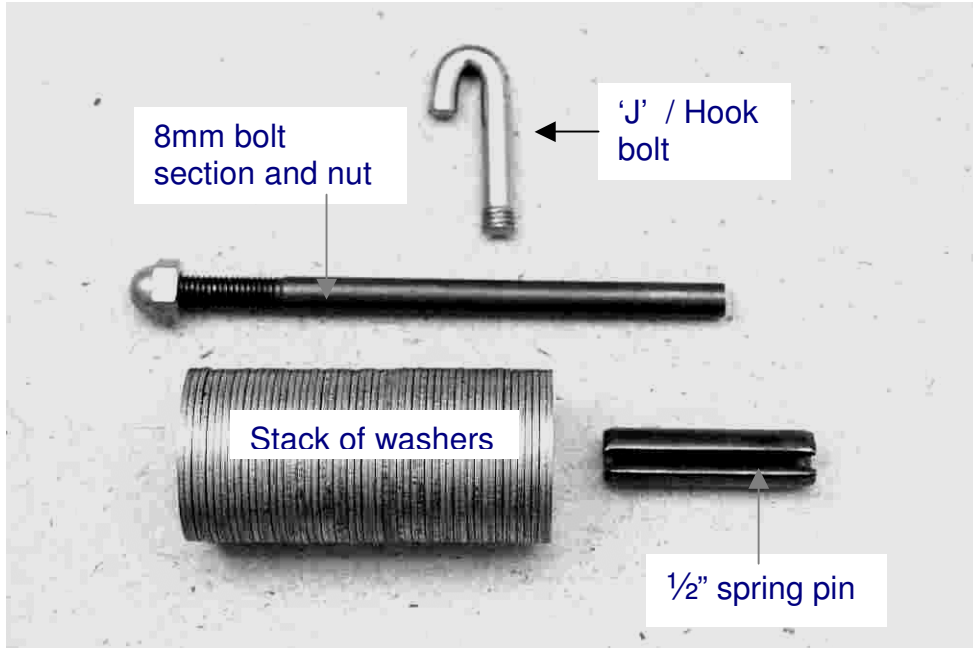

The components are fitted to the 8mm bolt section as shown below.

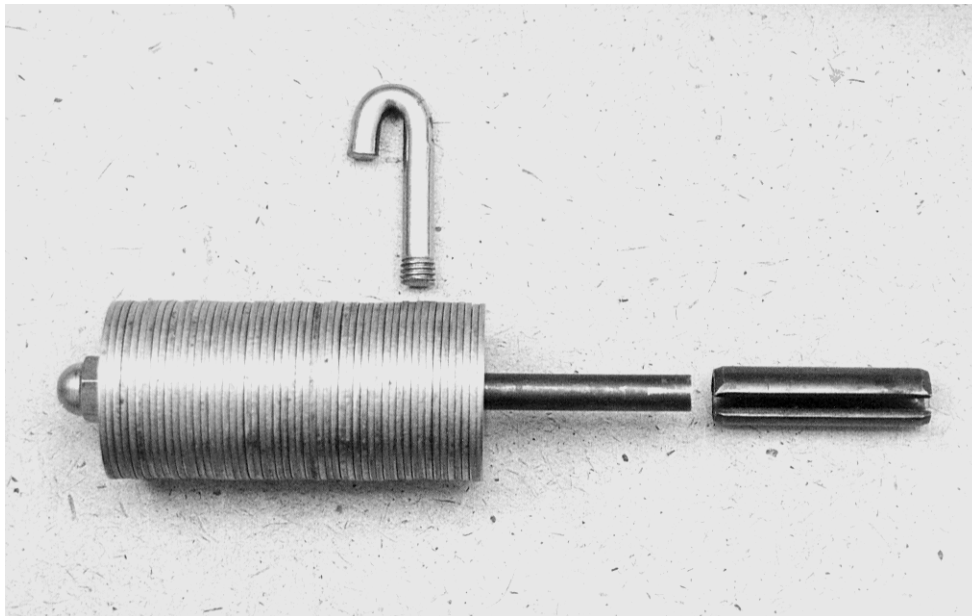

The 1/2" spring pin is two inches in length and is silver soldered to the end of an 8mm diameter high tensile bolt. The end of the bolt section being fitted with the firing pin prior to this.

A stack of 1 1/2" diameter washers (with 8mm holes) are then inserted over the bolt section and retained with a nut.

Around 52 washers are necessary to provide the bolt with the required length and weight.

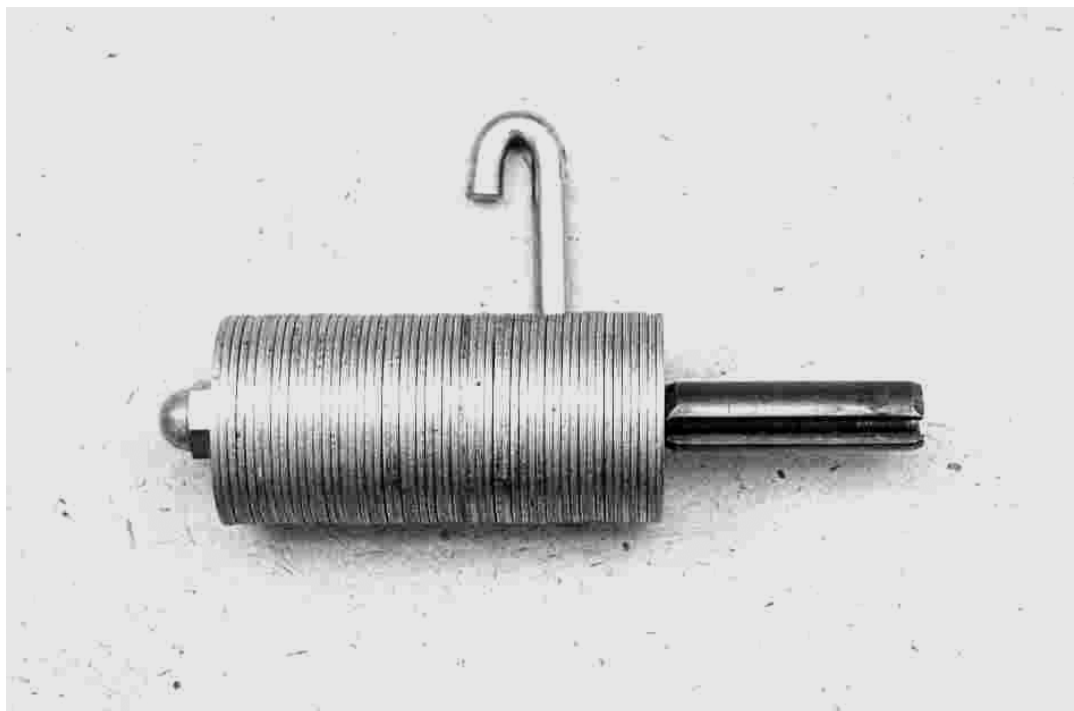

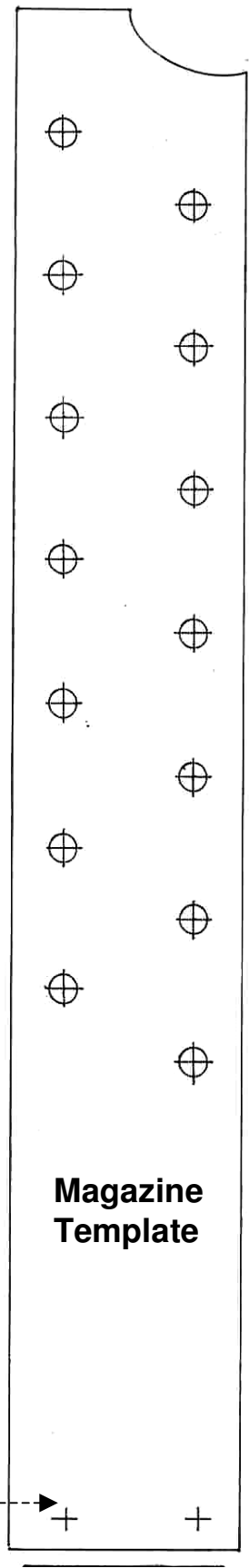

Drill two 2mm diameter holes through the Magazine body and cap to retain the cap in position.

The magazine body is 9" in length. If it is not this length when printed, the template should be enlarged using a photocopier until this measurement is achieved. The template is attached to a length of 34.93 x 15.88mm tubing.

A 34.93 x 15.88mm plastic tube cap is used to seal off the bottom of the magazine.

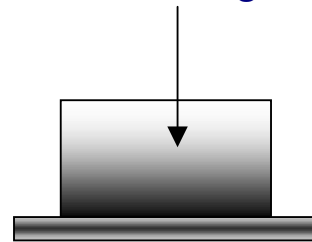

FITTING A SHOULDER STOCK

It is quiet possible to construct a simple folding shoulder stock for the BSP machine gun using nothing more than a modified 3/8" ratchet spanner and a length of steel tubing!

The following pages illustrate how this is done.

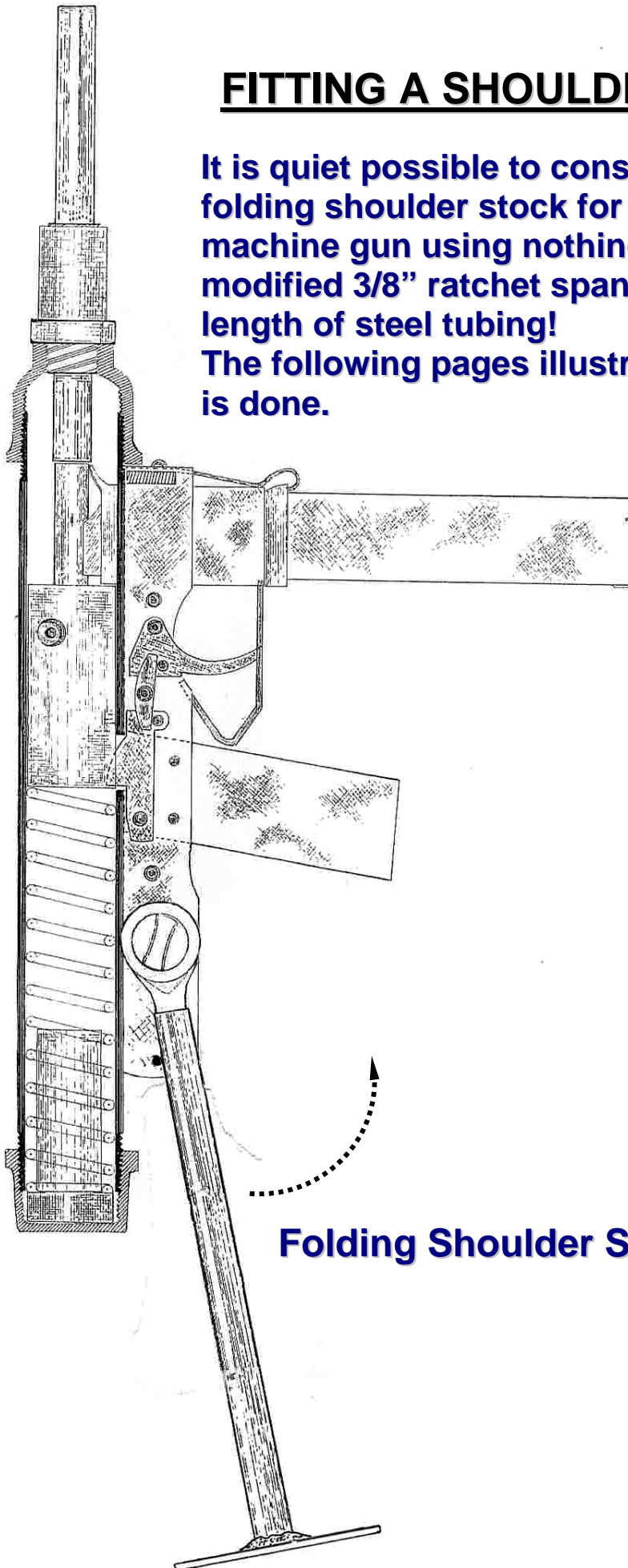

Folding Shoulder Stock.

PHOTO OF SHOULDER STOCK COMPONENTS

The shoulder stock is assembled from a 3/8" ratchet spanner, a length of 5/8" round tube, a section of 1/2" box tube, four washers, a cotter pin, and a length of 1" x 1/8" steel plate.

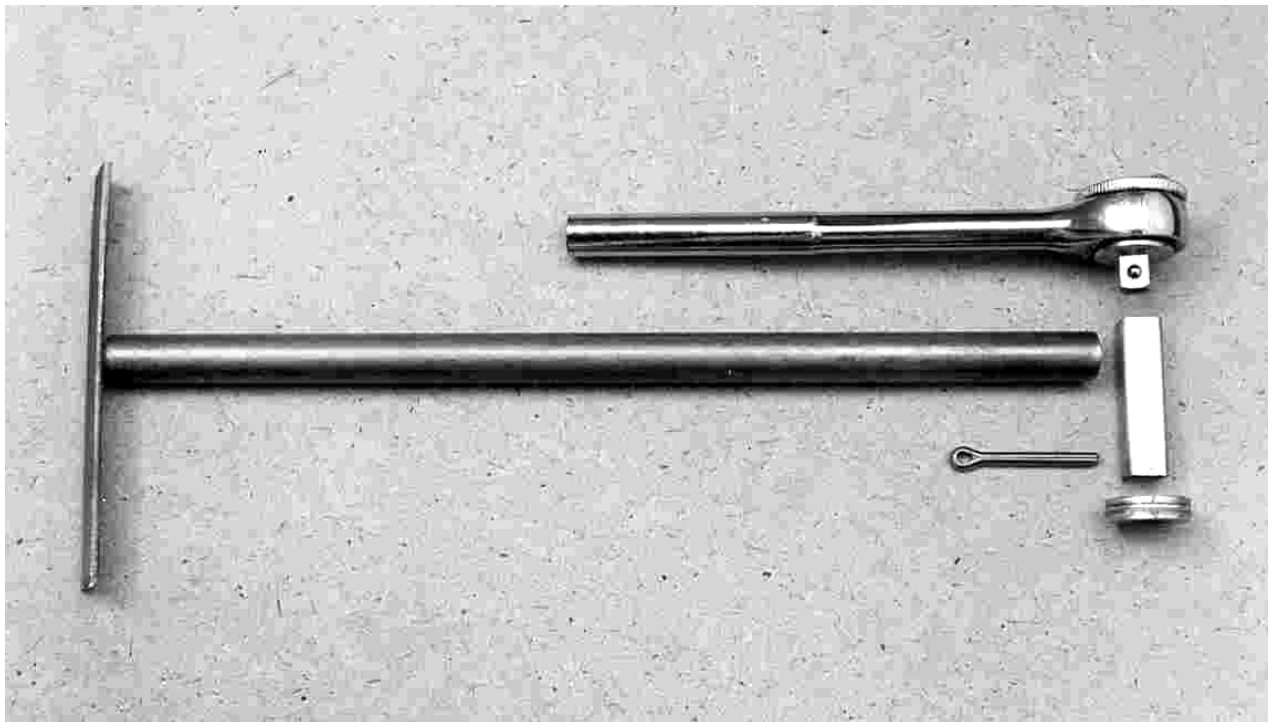

ASSEMBLING THE SHOULDER STOCK

MATERIALS REQUIRED

1. 3/8" ratchet spanner.
2. 5/8" x 16g steel tube.
3. 1/2" x 16g box section tube.
4. 1 1/4" washers x 3/4" hole.
5. Cotter pin x 1.

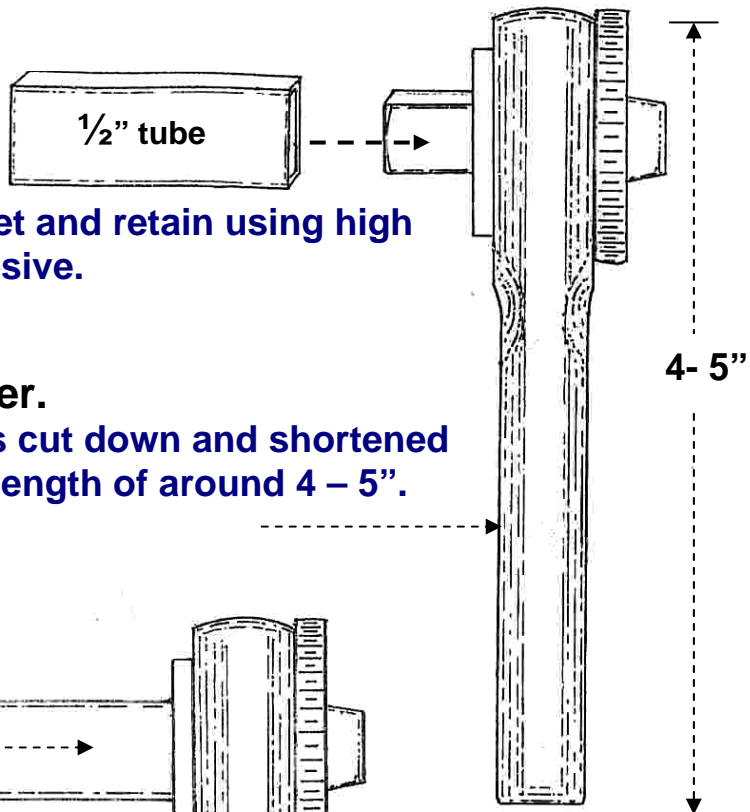

Insert tube onto ratchet and retain using high strength bearing adhesive.

3/8" Ratchet spanner.

The ratchet spanner is cut down and shortened until it has an overall length of around 4 – 5".

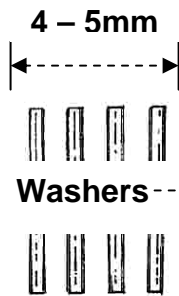

Slide washers onto tube.

A series of washers are placed over the 1/2" box section. These may consist of either four standard 'light' washers or two to three thick 'heavy' washers. Either way, the stack of washers must result in a combined length of 4 – 5mm.

REAR VIEW OF WEAPON SHOWING
SHOULDER STOCK ATTACHED TO
RECEIVER

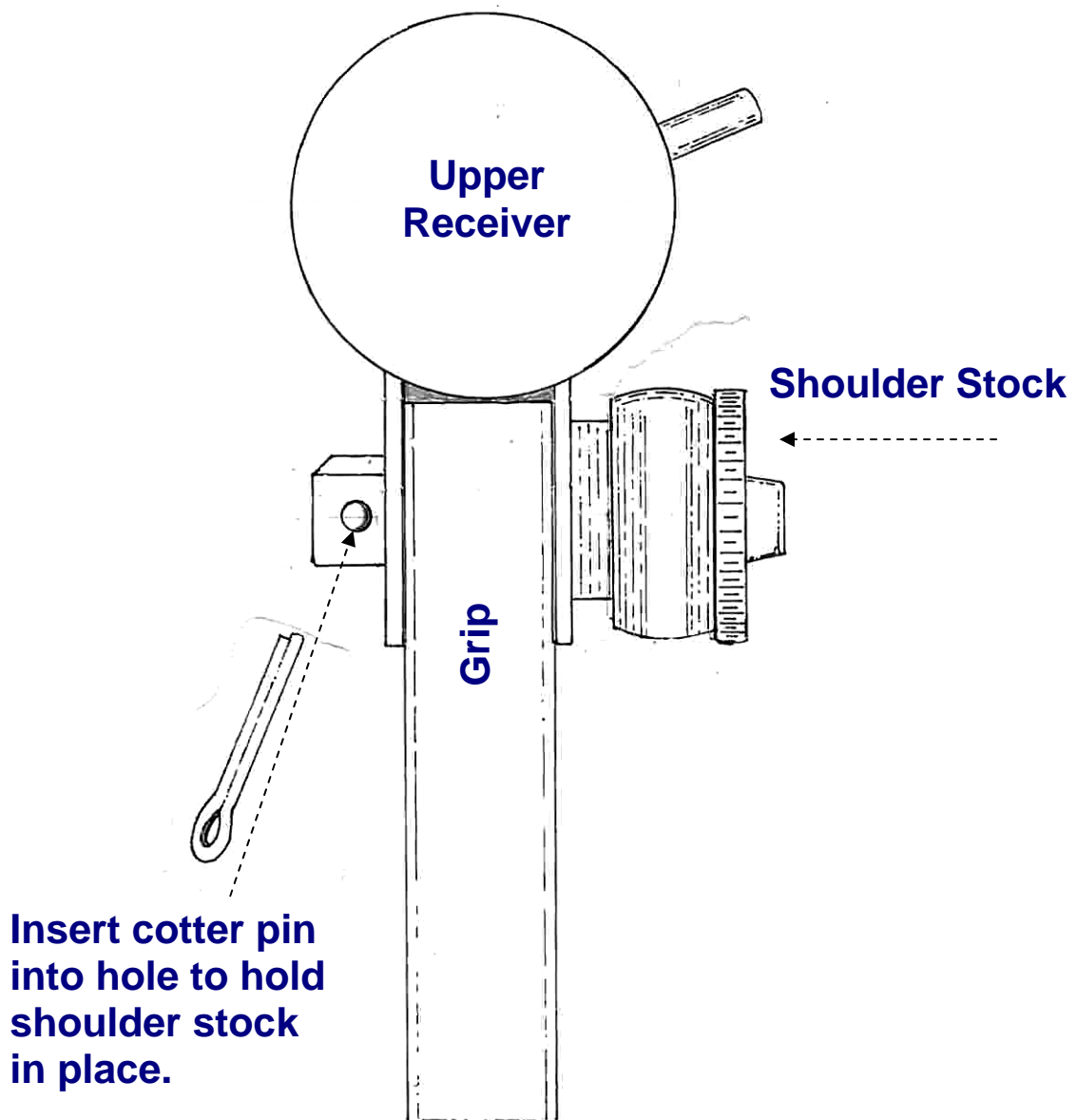

SHOULDER STOCK

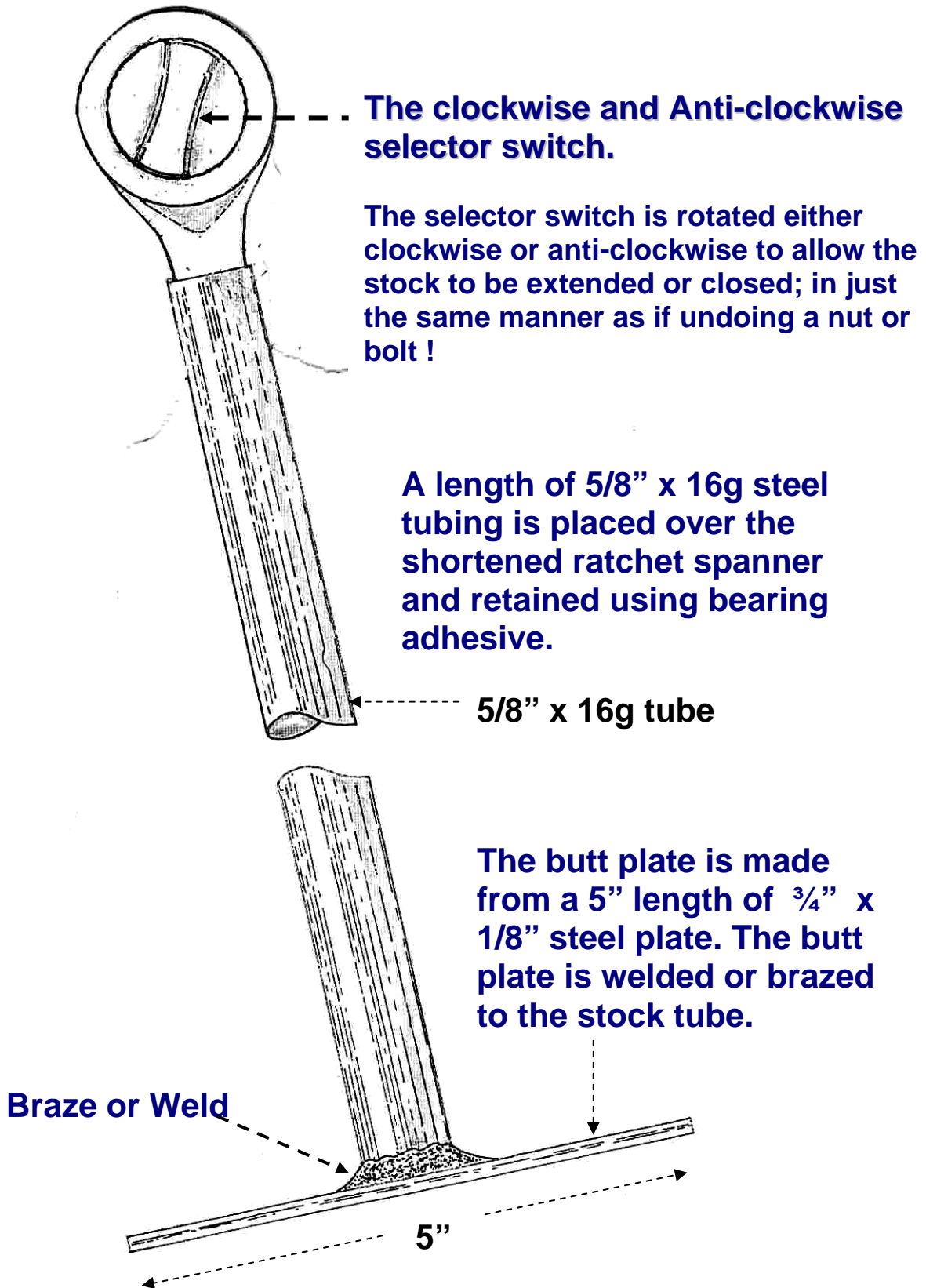

Construction notes:

1. Mainspring/ recoil spring; a suitable mainspring for the BSP machine gun can be acquired by stripping down a side lever grease applicator gun and removing the spring.

The spring illustrated below measures 216mm (8 ½”) in length and 30mm in diameter. The wire the spring is made from being 2mm in diameter.

This spring is almost perfect in dimensions for the BSP machine gun and was removed from the grease gun shown below. Spring sizes do vary depending on grease gun manufacturer.

2. Magazine; The magazine for the BSP machine gun is identical to that shown in my book *‘Expedient Homemade Firearms’ - The 9mm machine Gun*. See book for details.

3. Stock; The length of the shoulder stock can be adjusted to suit individual requirements by simply increasing or reducing the length of the stock tubing prior to final assembly.

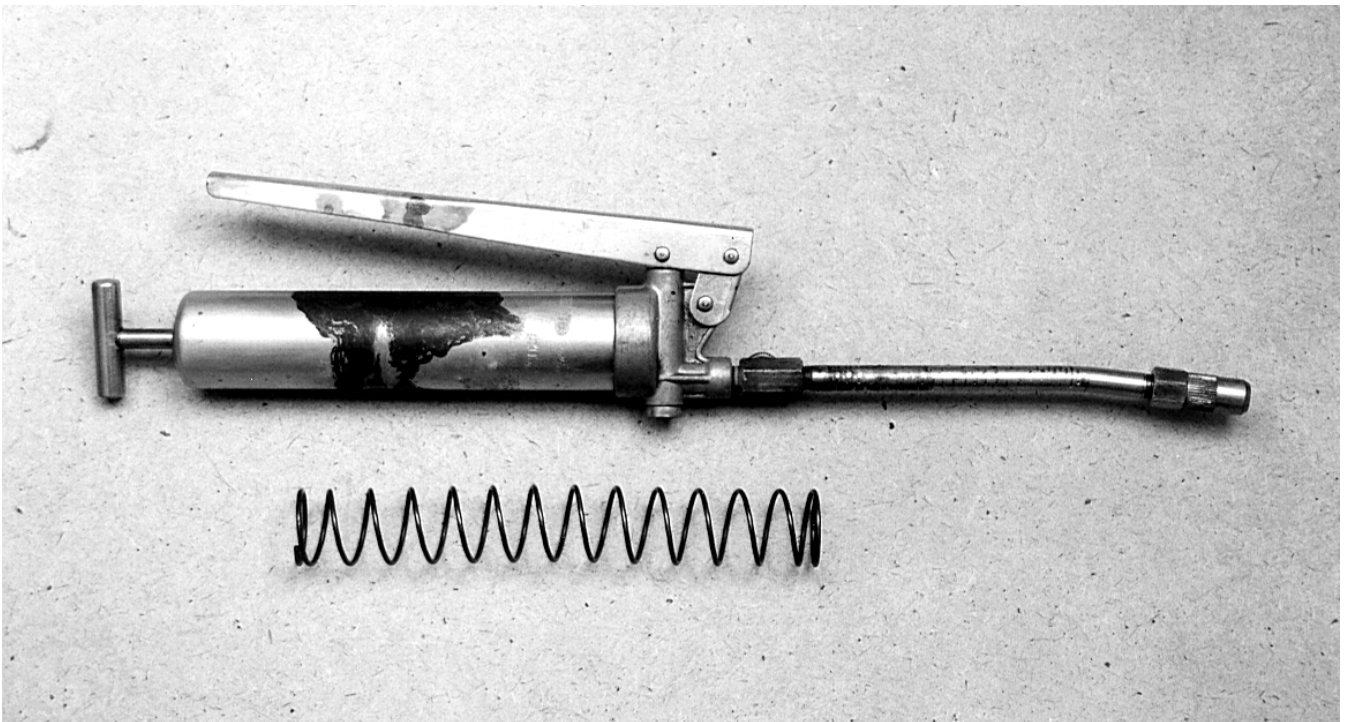

Side lever grease applicator and internal spring.